

Mod. IK ALK 1,5
Ref. / Cód. 8.17.77

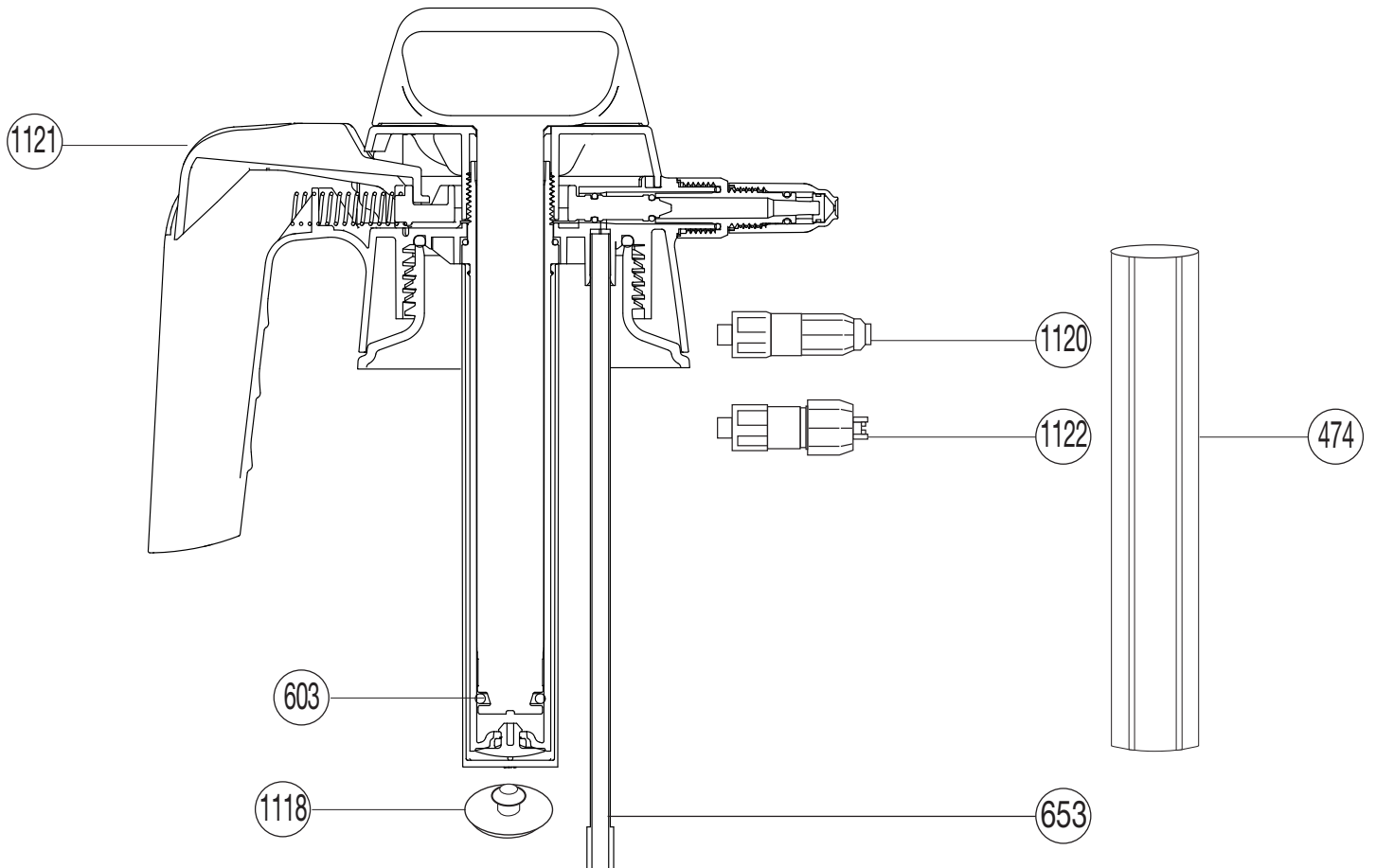
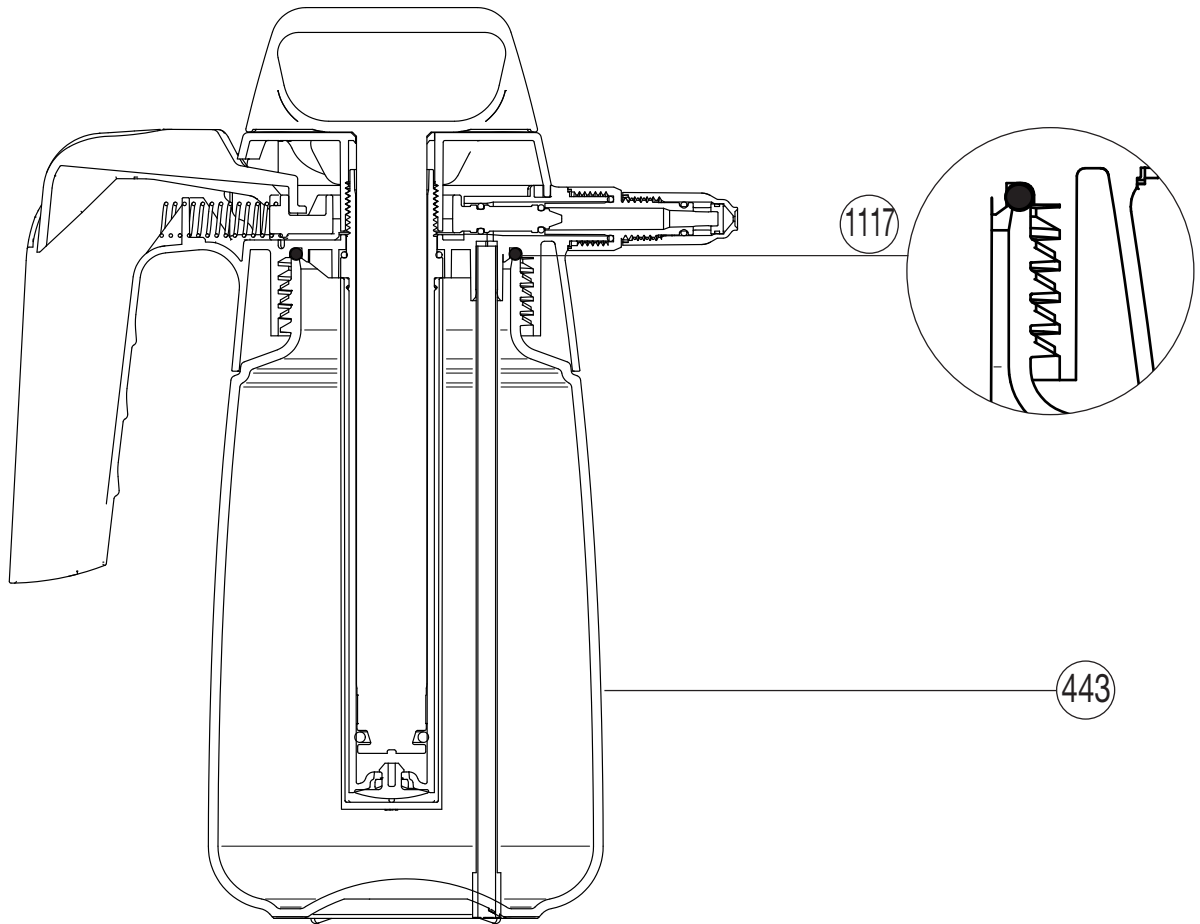

			ES RELACIÓN DE PIEZAS	FR LISTE DE PIÈCES	EN PARTS LIST	PT RELAÇÃO DE PEÇAS	DE ERSATZTEILLISTE	NL LIJST VAN ONDERDELEN
N°	COD.	Q	ES DENOMINACIÓN	FR DÉNOMINATION	EN DESCRIPTION	PT DENOMINAÇÃO	DE BENENNUNG	NL BENAMING
443	8.17.71.301	1	DEPÓSITO	RESERVOIR	TANK	DEPÓSITO	BEHÄLTER	RESERVOIR
474	8.17.71.305	1	PROTECTOR CILINDRO	PROTECTEUR CYLINDRE	CYLINDER GUARD	PROTECTOR CILINDRO	ZYLINDERSCHUTZ	CILINDERBESCHERMING
603	2.23.99.439.16	1	JUNTA REDONDA Ø15	JOINT ROND Ø15	ROUND GASKET Ø15	JUNTA REDONDA Ø15	RUNDDICHTUNG Ø15	RONDE PAKKING Ø15
653	8.28.27.320	1	FILTRO CON TUBO	TUYAU AVEC FILTRE	TUBE WITH FILTER	FILTRO COM TUBO	ROHR MIT FILTER	FILTER MET BUI
1117	2.23.17.990	1	JUNTA	JOINT	ROUND GASKET	JUNTA	RUNDDICHTUNG	PAKKING
1118	8.38.05.314.3	1	VÁLVULA CÁMARA	SOUPAPE DE LA CHAMBRE	CHAMBER VALVE	VÁLVULA CÁMARA	KAMMERVENTIL	KAMERKLEP
1120	8.17.77.601	1	ADAPTADOR M. 12 CON BOQUILLA CÓNICA REGULABLE	ADAPTATEUR M-12 AVEC BUSE CONIQUE À JET RÉGLABLE	M-12 ADAPTER WITH ADJUSTABLE CONICAL NOZZLE	ADAPTADOR M-12 COM BICO CÔNICO REGULÁVEL	VERBINDUNGSSTÜCK M-12 MIT EINSTELLBARER KONUSDÜSE	ADAPTER M-12 MET REGELBARE CONISCHE KOP
1121	8.17.77.801	1	CÁMARA COMPLETA	CHAMBRE COMPLETE	COMPLETE CHAMBER	CÁMARA COMPLETA	KAMMER KOMPLETT	COMPLETE KAMER
1122	8.17.77.602	1	ADAPTADOR M-18 CON BOQUILLA ABANICO	ADAPTATEUR M-18 AVEC BUSE MIROIR-ÉVENTAIL	M-18 ADAPTER WITH FAN NOZZLE	ADAPTADOR M-18 COM BICO JATO LEQUE	VERBINDUNGSSTÜCK M-18 MIT STRAHLDÜSE	ADAPTER M-18 MET WAAIERVORMIGE KOP
	8.17.77.200	1	HOJA INSTRUCCIONES	FEUILLE D'INSTRUCTIONS	INSTRUCTION SHEET	FOLHA INSTRUÇÕES	INSTRUKTIONSBLATT	INSTRUCTIEBLAD
	8.17.77.201	1	EMBALAJE	EMBALLAGE	PACKAGING	EMBALAGEM	VERPACKUNG	VERPAKKING